

Auger Boring Machines

Maxi-Rig & Mid-Size Directional Drills

Trenchers & Road Miners

Mud Pumps & Cleaning Systems

Tooling & Accessories



American Augers and Trenchor products are manufactured at the company's 241,000 square-foot facility in West Salem, Ohio, in the heart of Amish country between Columbus and Cleveland.

American Augers was the first HDD manufacturer to eliminate chain and utilize rack and pinion carriage design which is now the industry standard. Our rack and pinion drive provides smoother carriage movement, more precise operating control, long system life and no complicated parts.



P-750 Mud Pump



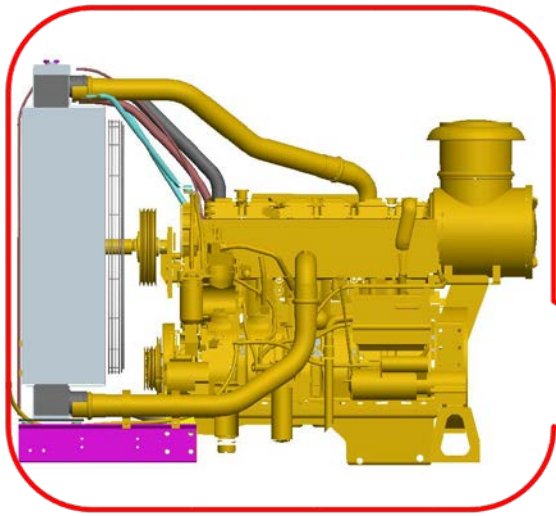

Engine: Caterpillar C-18 Tier III Diesel

Rating: 600 HP (447 kW)

Fuel Capacity: 300 U.S. Gallons (1,136 L)

Battery: (2x), Deka 908DMF 12 V, 1450 CCA



Engine

Weatherford Model Q700 Quintiplex Pump

Rated Capacity:

Continuous:

650 USG (2,460L) per min

Intermittent:

750 USG (2,839L) per min

Bore x Stroke

5.5" (140mm) x 7.9"
(200mm)

Maximum Pressure

1,500 PSI (103 bar)



Weatherford®

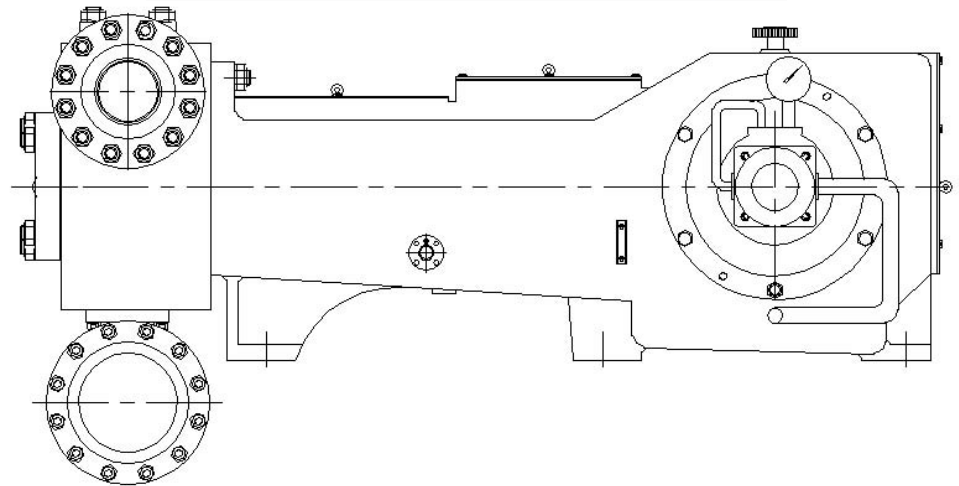

Pump



Eaton RTLO-22918B

10 Speed Manual
Transmission

15.5" (394mm) Twin Disc
Clutch, Air Actuated

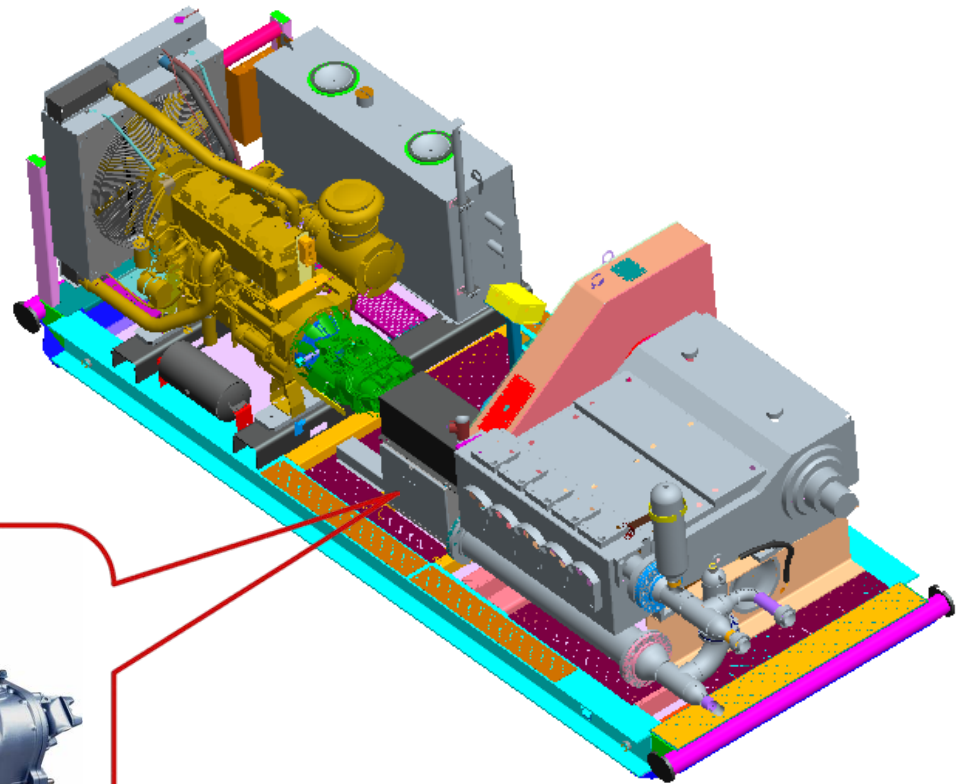

Transmission

Remote Control

- Start/Stop
- Throttle
- Clutch Actuator
- Horn

Remote Display

- Mud Flow
(GPM or LPM)



Control Panel

Dimensions/Weights:

Length: 25' 6" (7800mm)

Width: 8' (2438mm)

Height: 10' 3" (3120mm)

Est. Weight: 39,000lbs (17,690kg)

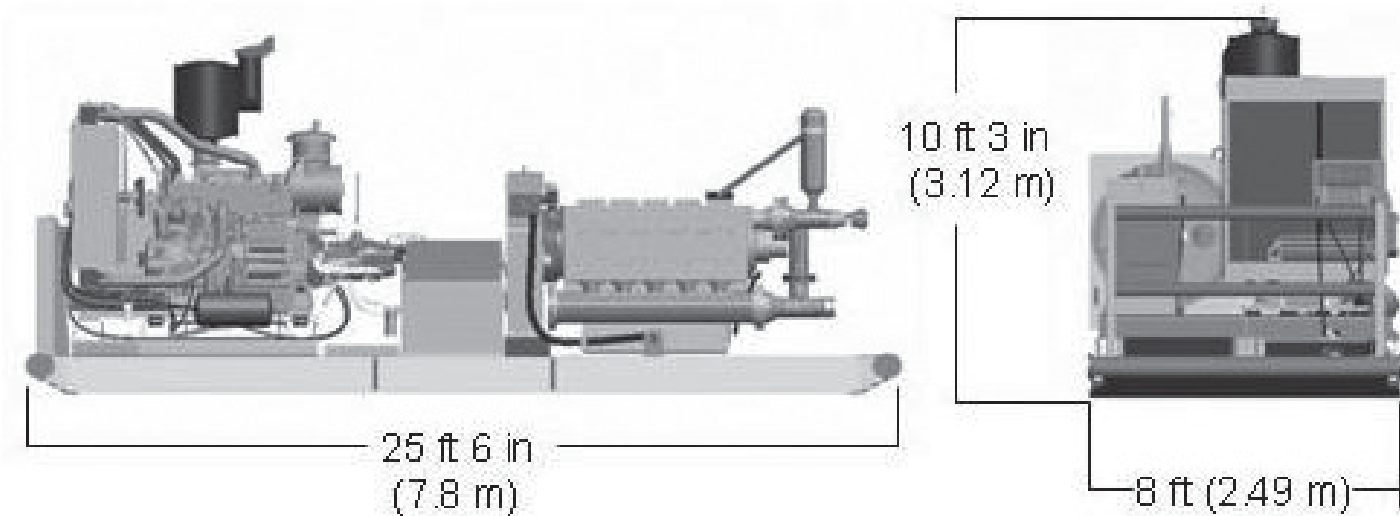

American Augers machines are supported through a dedicated parts and technical service department. We are here to help whenever you need us 24 hours a day, 7 days a week, emergency or not.

